

**Part Number:**  
KXA00402

**Models:**  
Himalayan  
(452cc only)

**WARNING:** Royal Enfield genuine accessories are designed to fit only the specific Royal Enfield motorcycle(s) that are specified above. They should not be fitted to any other type of motorcycle. Pay particular attention to the warnings and cautions contained in this instruction, failure to do so may result in an incorrect installation of the accessory which could result in an unsafe riding condition and possible accident. If in any doubt always seek help from your authorised Royal Enfield dealer.

**WARNING:** Before starting any accessory kit installation ensure the motorcycle is supported in a stable condition. Failure to support the motorcycle correctly could lead to motorcycle damage or personal injury.

**WARNING:** All fixings must be tightened to the torque values specified in this instruction. Failure to tighten fixings to the correct torque could result in an unsafe riding condition and possible accident

**CAUTION:** Care should be taken when fitting any accessory kit. Incorrect handling of kit components or the use of incorrect tools could lead to component or motorcycle damage.

**NOTE:** The content of this instruction is subject to change at any time without notice or liability. Royal Enfield reserves the right to revise the information presented at any time.



Item	Description	Qty
1	Handlebar Pad	1
2	Strap	1

**1** Loop the strap (1) through the two holes (2).

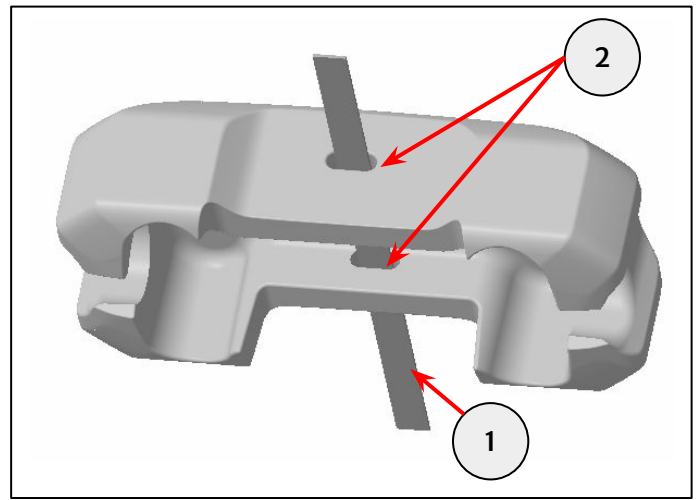

**2** Push the pad (1) onto the handlebar risers (2) until the pad clamps onto the handlebar (3)

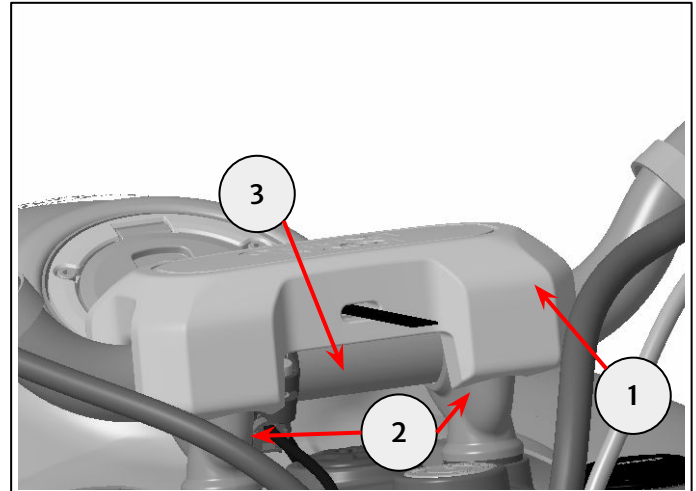

**3** Pass the strap under the handlebar (1) and overlap the hook and loop adhesive parts of the strap (2). Do not over tension the strap.

Periodically check the strap and pad for retention.

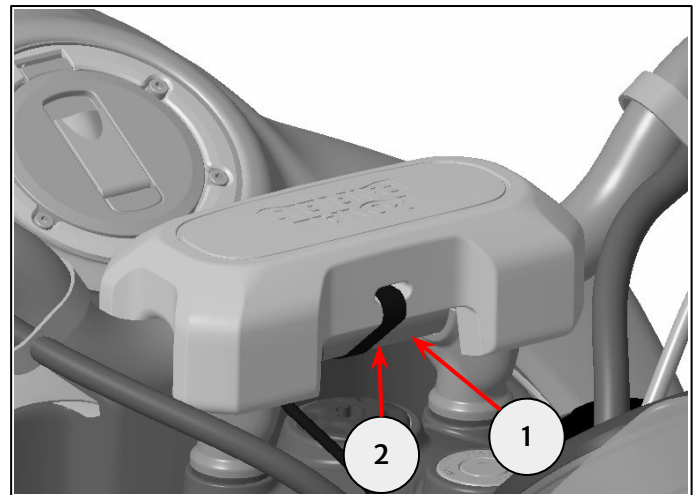

**WARNING:** After fitting any genuine Royal Enfield accessory always ride the motorcycle with caution and allow time to become familiar with any change in the motorcycle handling characteristics. Failure to become familiar with any change in the motorcycle handling characteristics may cause the motorcycle to become unstable and result in an accident.